



Tips and Ideas – Overcoming Vibrations in Milling

Most milling operations take place today on machining centers.

Milling operations on Compressor housings, Bell housings, Transmission housings and similar components involve the use of long reach Tool Assemblies. Such Milling Applications are prone to vibrations even at low cutting parameters.

Let's look at what we did to overcome vibrations in face milling of thin walled tractor housing as below:

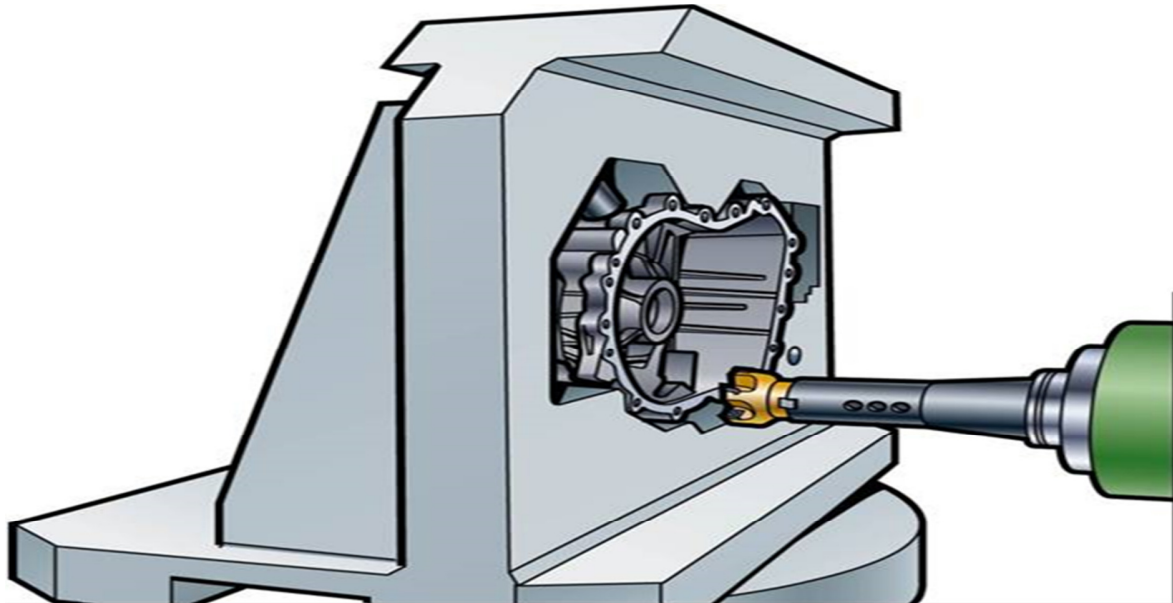

A 3-Step approach combining Good Milling Practice and "Out of Box" thinking enabled we eliminate vibrations with "near normal" cutting parameters. The 3 steps are outlined below.



Step1: Tool Holder related.

1. The machine had an HSK 63 interface which has a 2 face contact at the spindle interface.
2. In case HSK was not available and it's a Taper 40 or taper 50 interface then we need to reduce the deflection by placing shims at the back of the Tool Holder by measuring the exact distance between the spindle interface and start of the larger diameter of the taper – nominally @ 3.125mm and prepare a special profile steel shim that can be screwed on to the back face of the Tool holder.. see below:

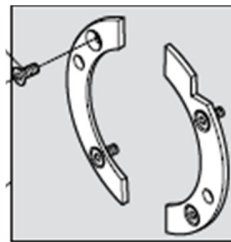
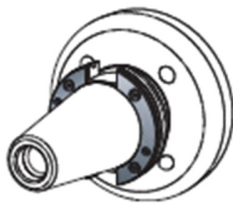

3. Use Modular extensions to build up the Gauge Plane length(GPL); An integral tool assembly is difficult to heat treat and can bend-giving rise to unbalances , which can propagate vibrations.

Step 2: Milling Cutter and Insert related.

In Milling operations where the Length of the Tool Assembly exceeds $L/D = 2$ the following tips and leads help in avoiding Vibrations as they reduce the Tangential and Radial components of the cutting forces that give rise to deflection:

- Use $V_c = 120 - 140 \text{ m/min}$ and Feed /Tooth F_z 0.15 to 0.25mm/tooth.
- Use light weight cutters so that the unbalanced mass stays at minimum.



- Select “light” cutting geometries and PVD coated insert grades.
- Select a differential pitch milling cutter (ie inserts placed at different pitch angles on its Diameter.
- If cutter available is of Even Pitch remove alternate inserts; this would double the Feed per Insert F_z , but still remain within the capacity of the insert.

Step 3: Tool paths and Parameter Optimization for Overhang Milling.

This is important, because in long overhang applications it is important to identify the combination of axial depth of cut and the percentage of Cutter engagement on the face being milled, that works the best.

- Start with depth of cut A_p @ 2mm.
- Selecting a Cutter approach angle 15 deg., 45 deg - that directs the cutting forces towards the spindle:

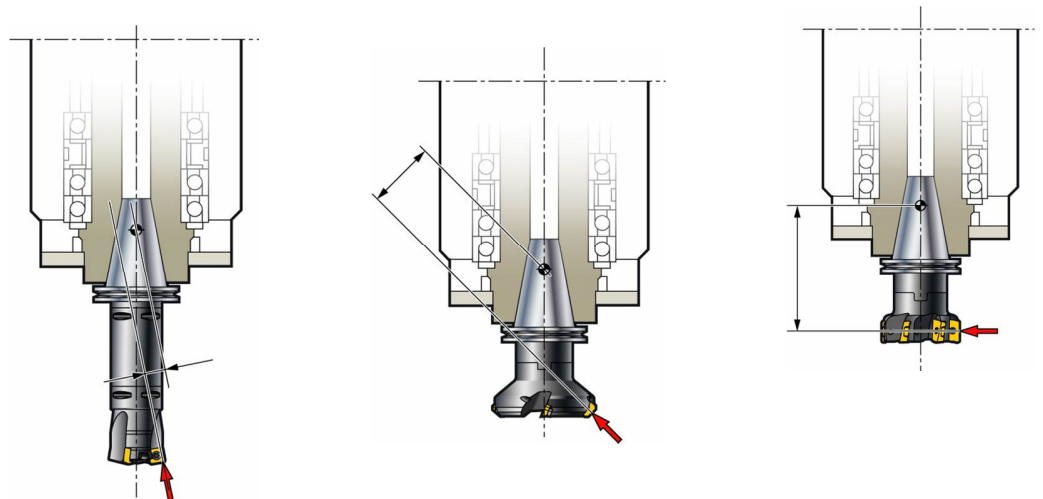

- Program Cutter Engagement at 20 to 25% of the width being milled.
- For Finish Pass use inserts with a higher nose radius.



- Make a "Roll on" type of Entry for the cut so that the loading on Insert is gradual (Thick chip on entry- thin at exit) – normally at 10 to 20degrees.
- Then we programmed a smooth engagement into the component face see against a direct radial entry – see below:

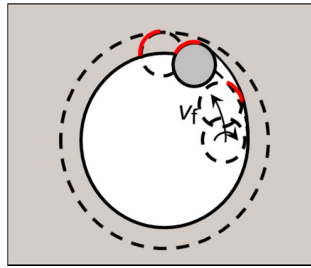
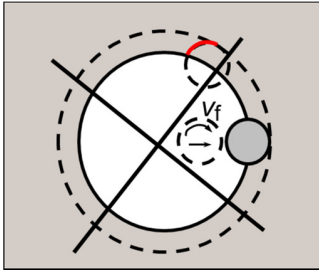

To summarize, we have a very small Window of Opportunity to avoid Vibrations in Milling; This Window can be identified quickly if we take the above approach and would in most cases avoid costly investments in Damped Tooling.